

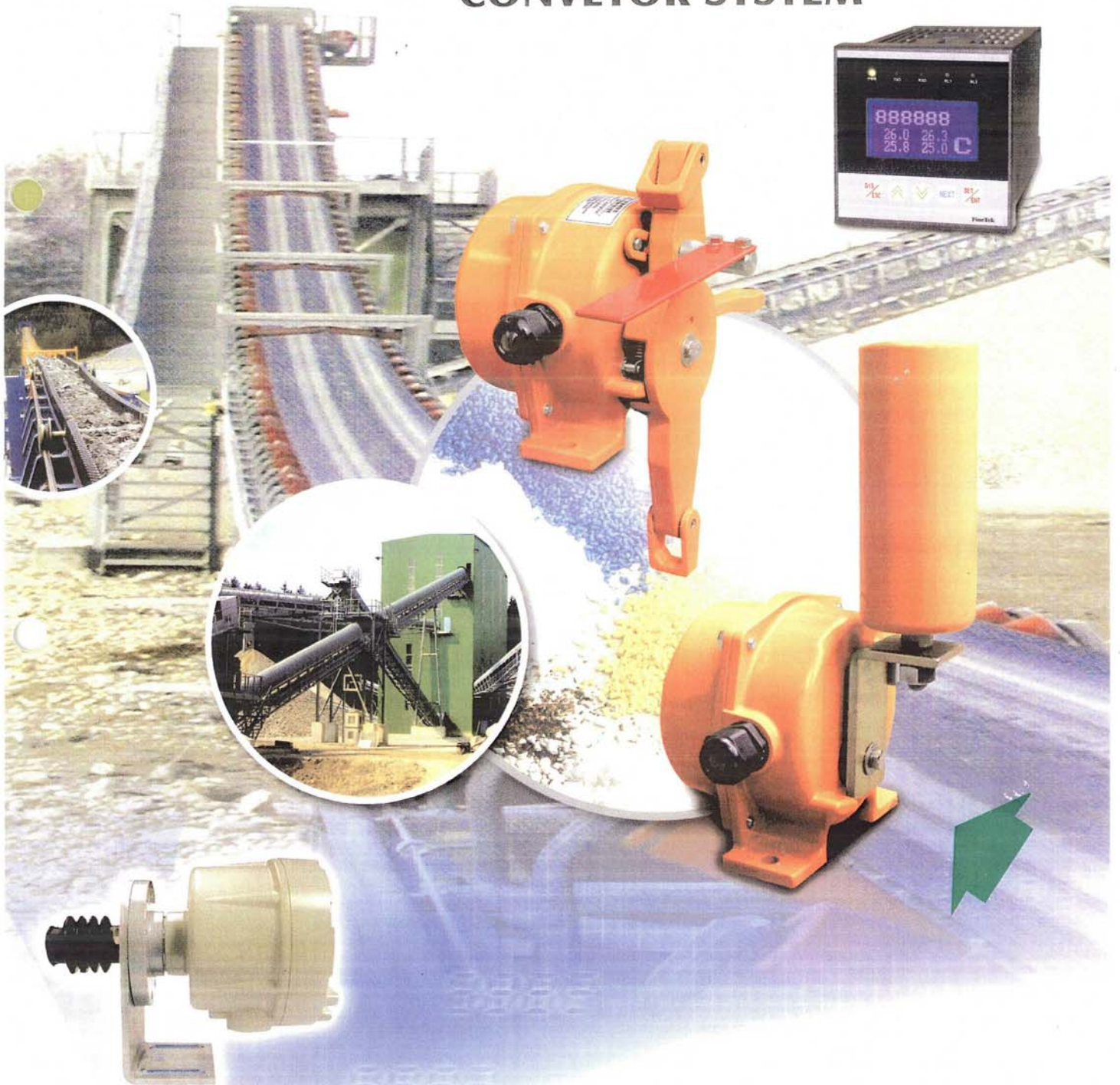

MONITORING DEVICES FOR CONVEYOR SYSTEM



INTERRUTTORE DI DISALLINEAMENTO
PER NASTRI TRASPORTATORI – **Modello SRT**

INTERRUTTORE DI DISALLINEAMENTO PER NASTRI TRASPORTATORI – Modello SRT

SRT

This device monitors the operation process for potentially hazardous conditions and activate an alarm when it is occurred misalignment, the SRT series conveyor belt misalignment switch protects the conveyor belt from damage due to belt misalignment or run off.

For normal condition, the belt misalignment switches are generally mounted on both sides and the edge of the conveyor belt.

A small clearance between the contact rollers and a little swaying for the belt edges are allowable. When the swaying exceeds the normal limit (on/ about 20 mm), the belt edge pushes the contact roller, which drives the switch and operates the contacts, the misalignment switch will reset automatically when the belt resumes normal running. These control devices are used in pair on each side of conveyor belt detected place, each unit can be equipped with two micro-switches to produce signals indicating the belt misalignment at two deviation points.

The first signal point could indicate small belt deviation by sounding an alarm, the second signal point could guard against extreme belt run off by shutting down the conveyor.

The roller is adjustable up to 20° in both directions and is positioned approximately 20mm from the conveyor belt, the switch actuation points are adjustable from 0° to 35° by a simple change of the actuating cams.

DIMENSION

SRT

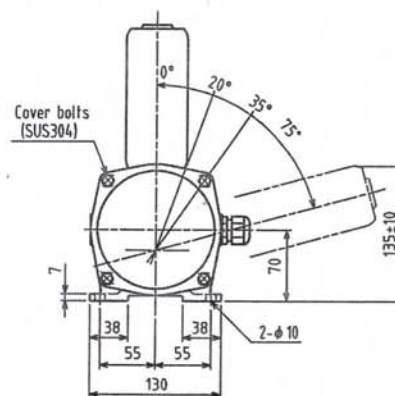
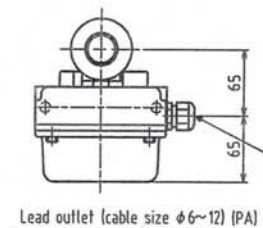
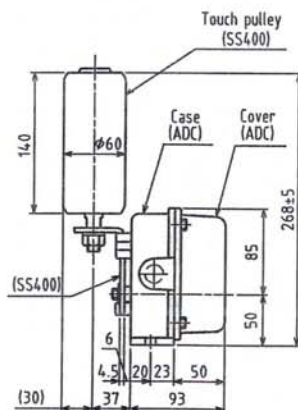

CHARACTERS

- Simple Installation, response sensitive
- Roller arm can move up to 75 degrees in either direction
- Dust tight, IP 67 weatherproof, Die cast aluminum housing
- Roller lever actuating angle 20° for alarm signal and 35° for shutting down system
- To Save Process downtime, product loss and replacing cost of damaged conveyor belt

APPLICATIONS

- Conventional Belt Conveyors
- Underground, Cable Supported Belt Conveyors
- Stacker / Reclaimer Conveyors
- Ship Loading / Unloading Systems
- Tripper and Shuttle Conveyors
- Crane / Shovel Boom Position Limit Detector
- Apron Feeders & Conveyors
- Heavy Duty Limit Switch

SPECIFICATION

Switching Capacity	10A, 125/250 Vac 1/2A 125 Vdc SPDTx2
Action Force	3.4~5.4N.m (0.35~0.55kgf.m)
Reset Way	Manual
Ambient Temp.	-20~60°C
Enclosure Protection Grade	IP67
Enclosure Material	Die cast ADC
Weight	Approx. 2.9kg

AGENTE DI ZONA RIVENDITORE AUTORIZZATO

IONet **ese** **MASAUTOMAZIONE**

I - 20090 SEGRATE (MI) - Via G. Galilei, 20
Tel. 02 26922090 (6 linee r.a.) - Fax 02 2135420 - 02 26921687
E-mail: info@masautomazione.it - www.masautomazione.it
Masautomazione è una società certificata ISO9001:2000